

MEADOS pH and ORP Measuring and Dosing System



Two Advanced Instruments in One

MEADOS pumps combine the powerful Blackstone dosing pumps with Hanna pH/ORP controllers. This latest innovation eliminates the need for multiple units by combining a pH controller and chemical feed pump into one. No more complicated installations, wiring and compatibility problems. This compact unit features accurate regulation, proportional dosing, alarm and recorder signals and much more, all in one meter.

Easy Installation

Designed with mounting holes built into a rugged base, Blackstone pump/controllers are simple to install. They use a standard pH probe with a BNC connector to eliminate the need for any additional hardware. All of the controls and pump assemblies are conveniently located on the front of the unit. There is no need to uninstall the unit to access the pump head or control panel.

Rugged Construction

Blackstone pump/controllers are housed in rugged, fiber-reinforced polypropylene IP55 rated casings to prevent the ingress of liquids. The material used for the housing resists corrosion caused by most chemicals, protecting the unit from hazardous spills and splashes.

Superior Materials

Blackstone pumps use PVDF, FPM/FKM and PTFE materials for all components in contact with the chemicals being dosed. These materials have properties which enable them to resist even the most corrosive chemicals in the industry. The chemical resistance chart on our BlackStone chemical dosing pumps section shows how well PVDF, FPM/FKM and PTFE resist the harmful effects of different products.

Simple Pump Action

A positive displacement solenoid with few moving parts makes Blackstone pumps more reliable than motor driven pumps since there is no rotating parts, gears or cams; drastically reducing any chance of mechanical failure.

Proportional Dosing

The Blackstone controller/pump strokes at full capacity when the measured value deviates by more than 1.5 pH or 150 mV from the set value. A proportional control slows down the stroke rate as the measured value approaches the user selectable set points, avoiding overdosage of chemicals. This feature makes the pump's dosing more accurate, saves chemicals and eliminates unnecessary and costly corrections to your process, especially with slow reacting chemicals.

Isolated Recorder Output

To enhance troubleshooting and the ability to record data while monitoring, Blackstone controller/pumps provide a recorder output. By simply attaching a recording device to the instrument's 4 to 20 mA output contacts, conveniently located on the front panel, you can obtain a hard copy of the results on demand.

Alarm Output

When monitoring and controlling pH and ORP levels in a process, it is very important that any potential problem does not go unattended. The Hanna MEADOS units incorporate an alarm system that will alert the user if the reaction is not within certain guidelines. The alarm of the BL7916 will be activated if the measured pH value is 2 pH units lower than the set point (if dosing acid, this indicates overdosage, a common symptom of siphoning). The alarm will also activate if the value is 2 pH higher than the set point (if dosing acid, this is an indication of insufficient dosage, a common symptom of the lack of chemicals). The BL7917's alarm will activate if the mV value is 200 mV lower than the set point (if dosing reducing chemicals, this indicates overdosage). The alarm will also activate if the value is 200 mV higher than the set point (if dosing reducing chemicals, this is an indication of lack of chemicals).

Auxiliary Dosing Contacts

The auxiliary dosing contacts of the MEADOS units are closed whenever the pump is dosing. This solution offers considerable advantages, especially for small plants, where these pumps need to be the only equipment left running. This will spare other equipment such as mixers, priming pumps etc. With this feature activated, a mixer can be automatically started, when the pump is dosing.

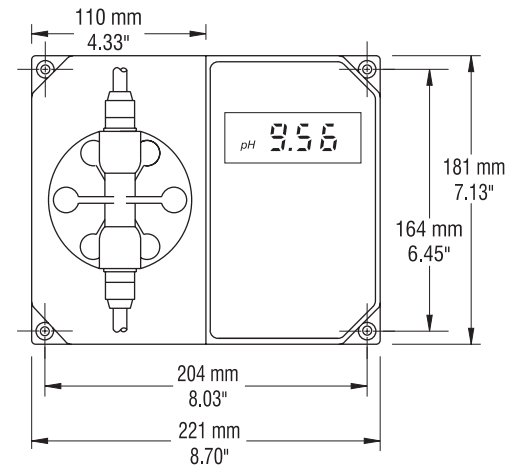

Front View

This series of instruments will mount easily in your plant using a minimum of wall space. The controls and pump head are located in the front to allow easy access.

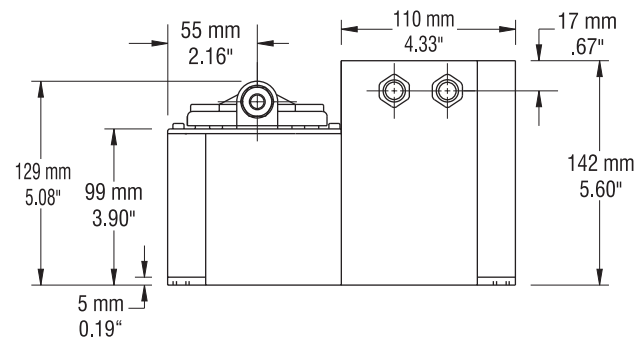

Bottom View

The controller/pump series of instruments are enclosed in a modular housing for maximum protection. These illustrations show the layout of the controller/pumps and how they utilize the one-piece polypropylene, injection-molded housing for rigidity.

Functional Description for BL7916

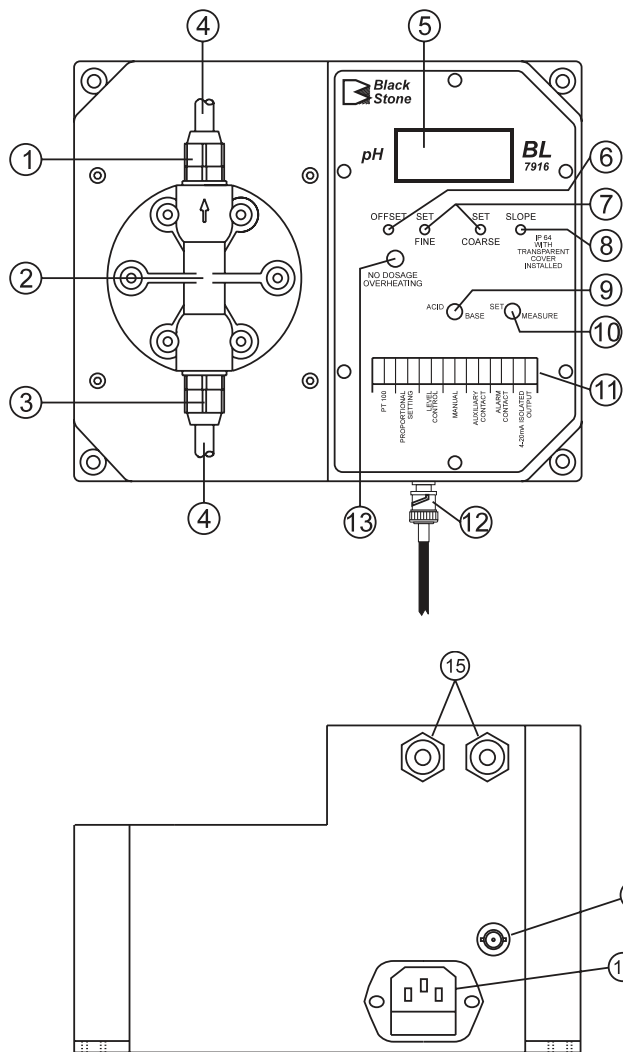

1. Discharge Valve Assembly
2. Pump head
3. Suction Valve Assembly
4. Hose
5. Liquid Crystal Display
6. Offset Calibration Trimmer
7. Setpoint Adjustment Trimmers (FINE and COARSE)
8. Slope Calibration Trimmer
9. Acid/Base Selection Switch
10. Display Mode Selection Switch (SET or MEASURE)
11. Terminal Connections
12. BNC Connector for pH electrode
13. Overheating LED
14. Power Socket and Fuse Holder
15. Cable Glands

Functional Description for BL7917

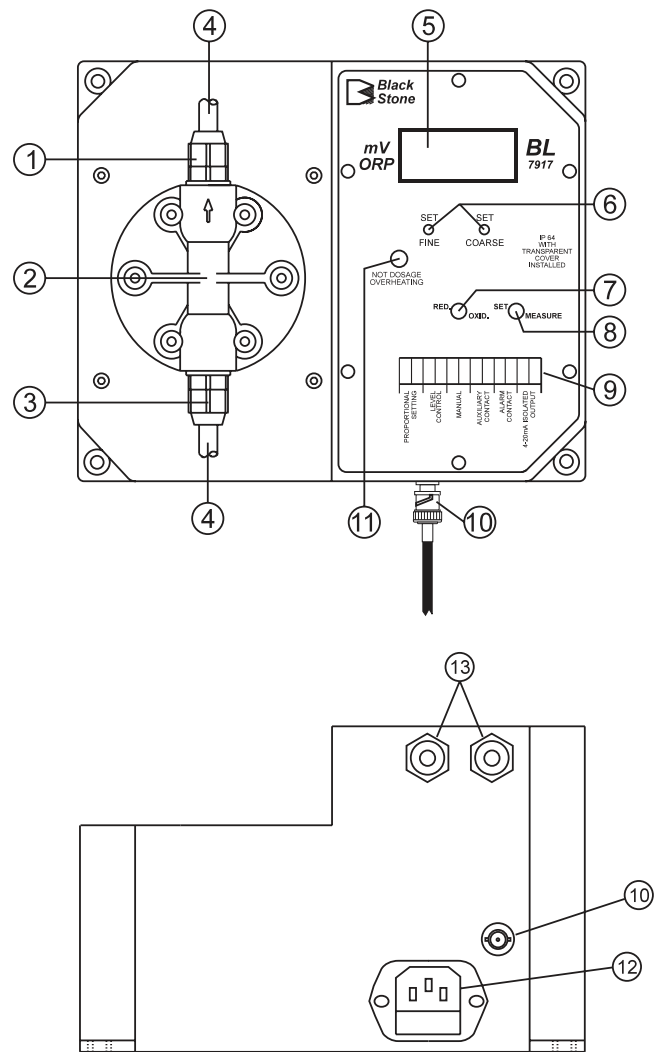

1. Discharge Valve Assembly
2. Pump head
3. Suction Valve Assembly
4. Hose
5. Liquid Crystal Display
6. Setpoint Adjustment Trimmers (FINE and COARSE)
7. Reduction/Oxidation Selection Switch
8. Operating Mode Selection Switch (SET or MEASURE)
9. Terminal Connections
10. BNC Connector for ORP electrode
11. Overheating LED
12. Power Socket and Fuse Holder
13. Cable Glands

BL7916

pH Controller and Pump

- pH controller and dosing pump
- ± 0.01 pH accuracy
- Isolated 4 to 20 mA recorder output.
- Proportional dosing
 - Slows the pump down when the measured pH level approaches the set value, which ensures precise dosage and avoids costly waste of chemicals due to overdosage.
- Alarm contact
 - Activated whenever the pH value varies more than 2 pH units from the set point.
- Auxiliary contacts
 - Allow the user to attach a mixer or priming pump that is activated only when the pump is dosing.
- PVDF, FPM/FKM and PTFE materials
 - Used for all parts that come into contact with liquid.



 **Black Stone**
by Hanna

Specifications	BL7916
Range	0.00 to 14.00 pH
Resolution	0.01 pH
Accuracy (@25°C/77°F)	± 0.01 pH
Flow Rate	see table
Input Impedance	10^{12} Ohm
Dosage	proportional, acid or base, user selectable
Dosing Contact	1 isolated, 2A, max. 240V, resistive load, 1,000,000 strokes
Alarm Contact	1 isolated, 2A, max. 240V, resistive load, 1,000,000 strokes
Calibration	offset: ± 1 pH with trimmer; slope: 85 to 115% with trimmer
Recorder Output	4-20 mA (isolated)
Power Supply	BL 7916-1: 115V $\pm 15\%$; 50/60Hz (40W); BL 7916-2: 230V $\pm 15\%$; 50/60Hz (40W)
Environment	0 to 50°C (32 to 122°F); RH max 95% non-condensing
Dimensions	221 x 142 x 181 mm (8.7 x 5.6 x 7.1")
Weight	5 kg (11 lb.)
Ordering Information	BL7916-1 is supplied with discharge and suction valves, polyethylene tubing, 115V power cable and instructions BL7916-2 is supplied with discharge and suction valves, polyethylene tubing, 230V power cable and instructions

BL7916 PRESSURE/FLOW

BAR (PSI)	LPH (GPH)
0.5 (7.4)	13.3 (3.46)
1.0 (14.7)	11.7 (3.04)
2.0 (29.4)	10.1 (2.63)
3.0 (44.1)	9.0 (2.33)
4.0 (58.8)	7.8 (2.03)



BL7917

ORP Controller and Pump

- ORP controller and dosing pumps
- ± 5 mV accuracy
- Isolated 4 to 20 mA recorder output.
- Proportional dosing
 - Slows the pump down when the measured ORP level approaches the set value, to avoid over dosage of oxidizing or reducing agents.
- Alarm contact
 - Is activated whenever the ORP reading varies more than 200 mV from the setpoint.
- Auxiliary contacts
 - Allow users to attach a mixer or priming pump that is activated only when the pump is dosing
- PVDF, FPM/FKM and PTFE materials
 - are used for all parts that come into contact with liquid.

Specifications	BL7917
Range	-999 mV to +999 mV
Resolution	1 mV
Accuracy (@25°C/77°F)	± 5 mV
Flow Rate	see table
Input Impedance	10^{12} Ohm
Dosage	proportional, oxidizing or reducing, user selectable
Dosing Contact	1 isolated, 2A, max. 240V, resistive load, 1,000,000 strokes
Alarm Contact	1 isolated, 2A, max. 240V, resistive load, 1,000,000 strokes
Recorder Output	4-20 mA (isolated)
Power Supply	BL 7917-1: 115V $\pm 15\%$; 50/60Hz (40W) BL 7917-2: 230V $\pm 15\%$; 50/60Hz (40W)
Environment	0 to 50°C (32 to 122°F); RH max 95% non-condensing
Dimensions	221 x 142 x 181 mm (8.7 x 5.6 x 7.1")
Weight	5 kg (11 lb.)
Ordering Information	BL7917-1 is supplied with discharge and suction valves, polyethylene tubing, 115V power cable and instructions. BL7917-2 is supplied with discharge and suction valves, polyethylene tubing, 230V power cable and instructions.

BL7917 PRESSURE/FLOW

BAR (PSI)	LPH (GPH)
0.5 (7.4)	13.3 (3.46)
1.0 (14.7)	11.7 (3.04)
2.0 (29.4)	10.1 (2.63)
3.0 (44.1)	9.0 (2.33)
4.0 (58.8)	7.8 (2.03)